

**Sumitomo Drive Technologies**  
*Always on the Move*

**PARAMAX<sup>®</sup>**  
YHD Series  
For Palm Oil Industry



CATALOGUE  
SCA.POM02/2012.05

# PARAMAX<sup>®</sup> YHD Series For Palm Oil Industries

## Features

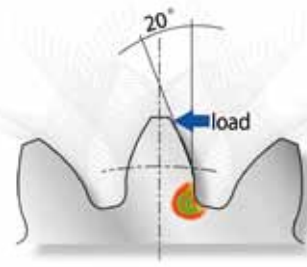

Pressure Angle 20°  
(Conventional Gears)

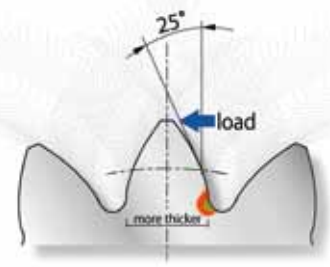

Pressure Angle 25°  
(Sumitomo PARAMAX<sup>®</sup> Series)

### Gears

- > Carburized Alloy Steel SCM822H
- > Surface hardness HRC58-62
- > Increase strength ratio with 25° pressure angle
- > Hardened & precision ground finish

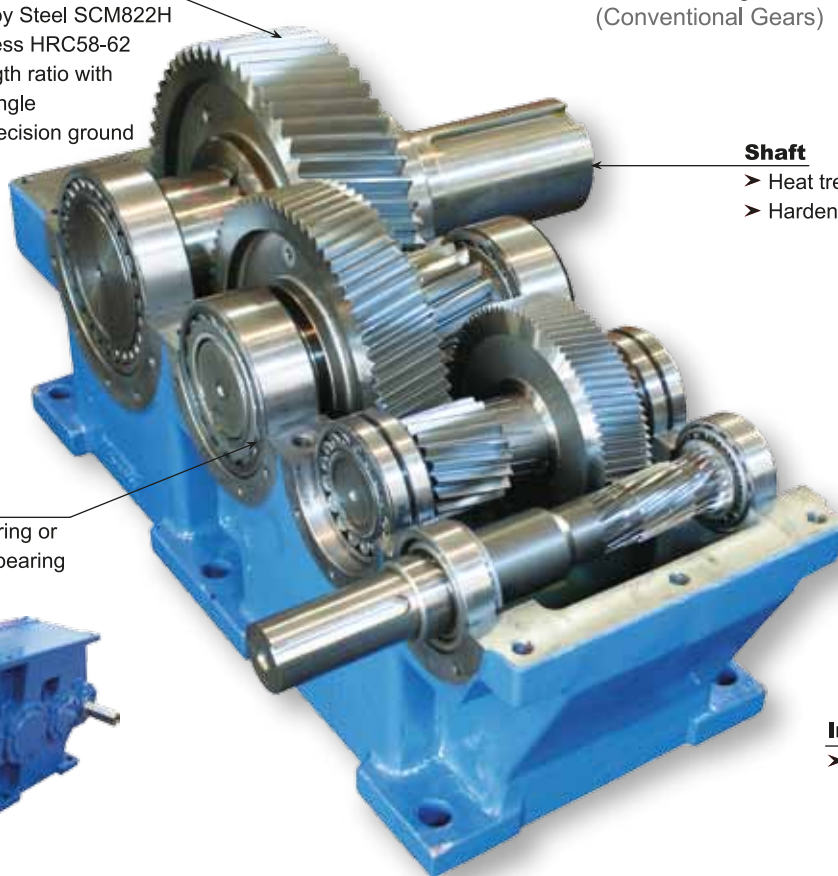

### Shaft

- > Heat treated alloy steel SCM440H
- > Hardened & ground finish

### Bearings

- > Taper roller bearing or Spherical roller bearing



### Oil gauge

- > Bulls eye oil gauge

### Housing

- > Machined top surface



### Installation

- > Housing designed to facilitate easy installation and removal of fasteners

### SUMITOMO PARAMAX<sup>®</sup> GEARBOXES FEATURES AND BENEFITS

<u>Features</u>	<u>Benefits</u>
AGMA Quality grade 12 gearing	Low noise, Higher capacity & Higher Efficiency
Protuberance hobbing	Eliminates stress concentration
Tip relief and Crowning	Improves contact, reduces noise level.
Pressure angle: 25 degrees	Increases strength
Helix Angle: 14 degrees	Reduces noise level
Vacuum Carburising	Removes impurities, reduces residual stresses
Vacuum degassed alloy steel	Consistent quality, prevents stress concentration due to impurities
Reinforced Cast Iron Housing	For reduced weight and optimum strength
Dual Lip Oil Seals	Prevents oil leaks and water intrusion
Locally stocked	Quick delivery
Local service teams	Prompt service and monitoring

## General Specifications

Application	Model	Ratio	Torque (Nm)	Allowable Radial Load on LSS (N)	Flippable Housing	Contents Page
Kernel Expeller Drive	YHD080P3-LR-55.066	55.066	74,000	140,000	-	3
Screw Press Drive (P15)	YHD060P3SP-RL-55.391	55.391	48,000	60,000	O	4
	YHD060P3SP-RL-78.456	78.456	45,000	60,000	O	4
Screw Press Drive (P20)	YHD080P3SP-RL-76.353	76.353	74,000	140,000	-	5
	YHD070P3SP-RL-77.373	77.373	70,000	87,000	O	6
Digester Drive (3000L)	YVA040P3DG-RL-57.962	57.962	18,000	37,000	-	7
Digester Drive (6000L)	YVD060P3DG-RL-57.328	57.328	32,000	60,000	-	8
Empty Fruit Bunch Press Drive	YHD080P3-LR-55.066	55.066	74,000	140,000	-	9

AMBIENT CONDITIONS	
Ambient Temperature	10deg C ~ 50deg C
Ambient Humidity	Under 85%
Elevation	Less than 1000m above sea level
Atmosphere	Well Ventilated location, free of corrosion and explosive gases, vapor

PAINT SPECIFICATIONS	
Surface Preparation	SIS Sa 2 1/2 (Inside & Outside)
Inside Paint	Modified Alkyd Resin Primer (20~40 μm)
Outside Paint	Primer: Modified Alkyd Resin Primer (40~80μm) Finish: Acrylic Alkyd Resin Paint (15~30 μm)
Paint Color	Donau Blue (Musell 6.5PB 3.6/8.2)

TEMPERATURE CORRECTION FACTOR	
Ambient Temperature (deg C)	Correction Factor
20	1
30	0.85
40	0.7
50	0.55

TECHNICAL NOTES
1. Lubrication: Oil Bath: Please use correct Oil Viscosity
2. Temperature correction factor must be used when calculating thermal capacity of the gearbox
3. Please ensure applicable radial load is lower than the Radial Load Capacity
4. All Gear Ratings are based on ISO 6336-1996
5. Key and Keyways are based on JIS B 1301-1996 Parallel key in fastening type (ISO R773-1969 Close Keys)

# Kernel Expeller Drive

YHD080P3-LR-55.066

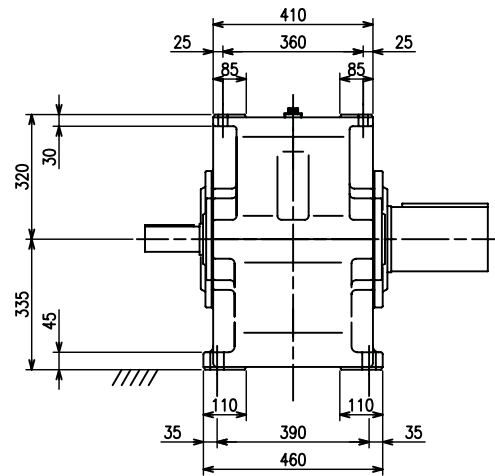
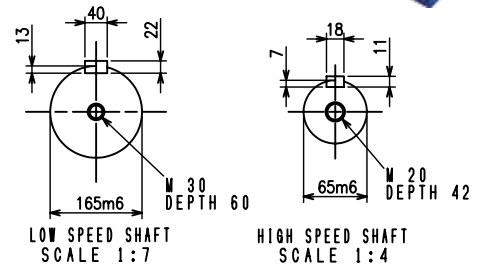
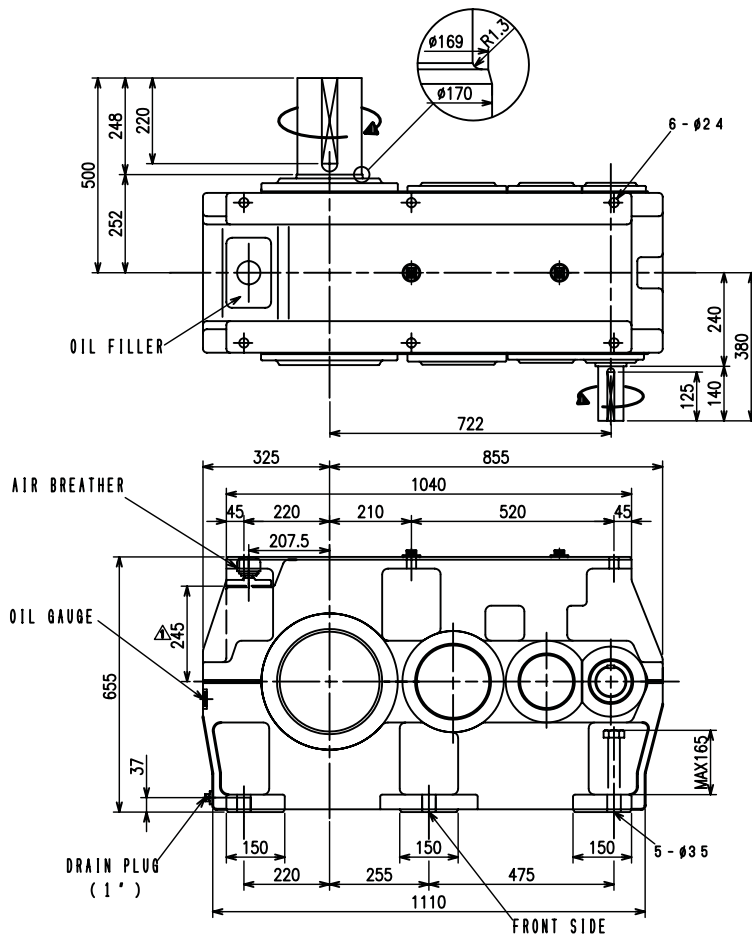

## KERNEL EXPELLER DRIVE REDUCER SPECIFICATIONS

Model	Ratio	Torque Rating Nm	Input Speed rpm	Output Speed rpm	Power Rating kW	Output Shaft dia mm	Input Shaft Dia mm	Weight (Approx) kg	Oil Qty (Approx) l
YHD080P3-LR-55.066	55.066	74000	1000	18.2	140	165	65	1000	65
			900	16.3	126				
			750	13.6	105				

Lubrication System Oil Bath  
Lubricant ISO VG220 AGMA 7EP

# Screw Press Drive P15

YHD060P3SP-RL-55.391/78.456

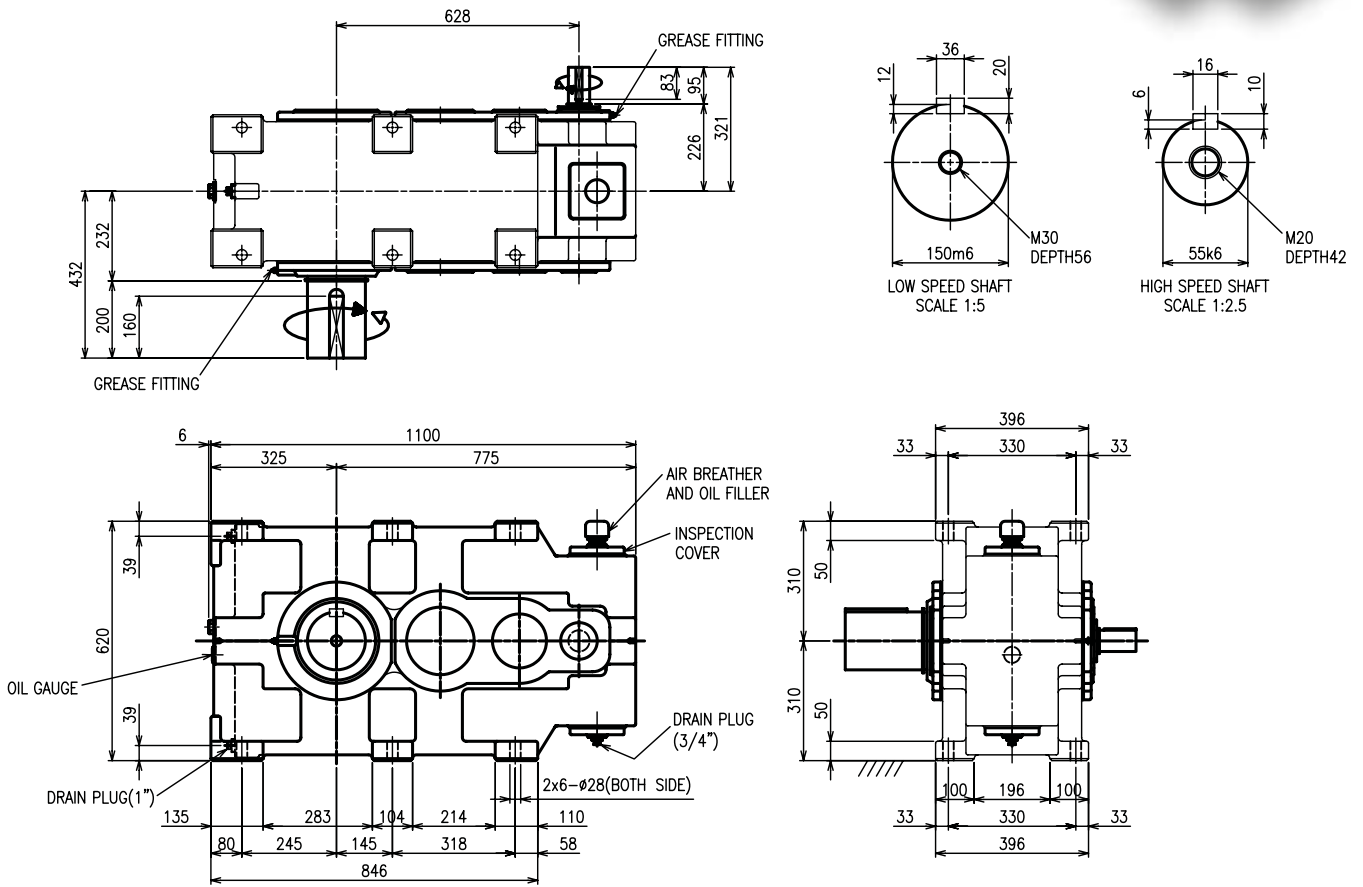
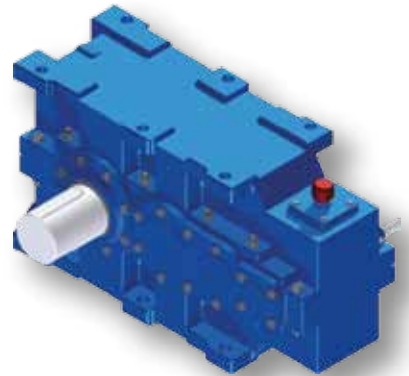

## SCREW PRESS DRIVE 15T (P15) REDUCER SPECIFICATIONS

Model	Ratio	Torque Rating Nm	Input Speed rpm	Output Speed rpm	Power Rating kW	Output Shaft dia mm	Input Shaft Dia mm	Weight (Approx) kg	Oil Qty (Approx) l
YHD060P3SP-RL-55.391	55.391	48,000	1000	18.1	90	150	55	730	60
			750	13.5	68				
YHD060P3SP-RL-78.456	78.456	45,000	1000	12.7	60	150	55	730	60
			750	9.6	45				

Lubrication System Oil Bath  
Lubricant ISO VG460 AGMA 7EP

# Screw Press Drive P20

YHD080P3SP-LR-76.353

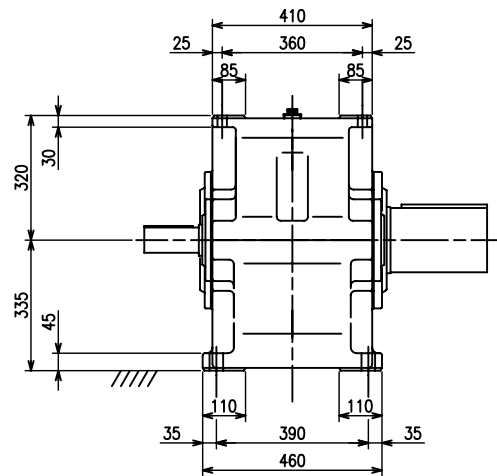
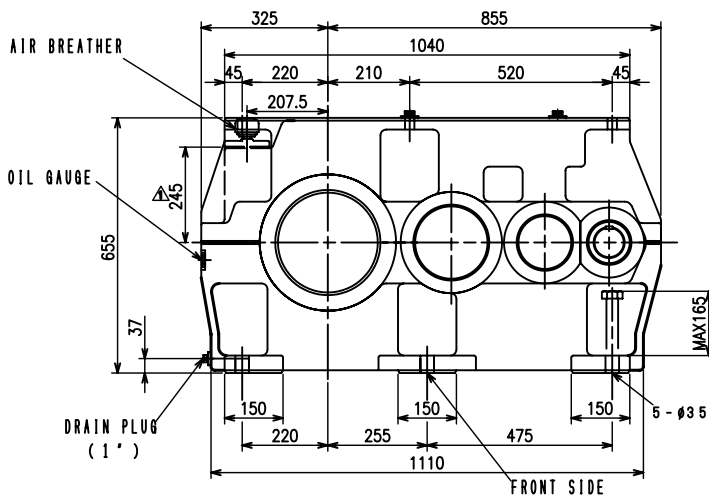
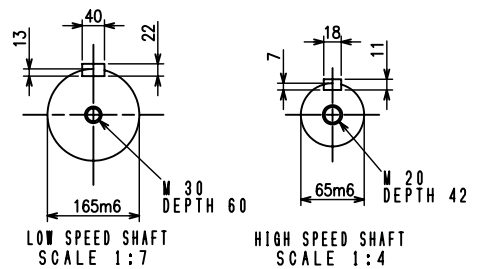
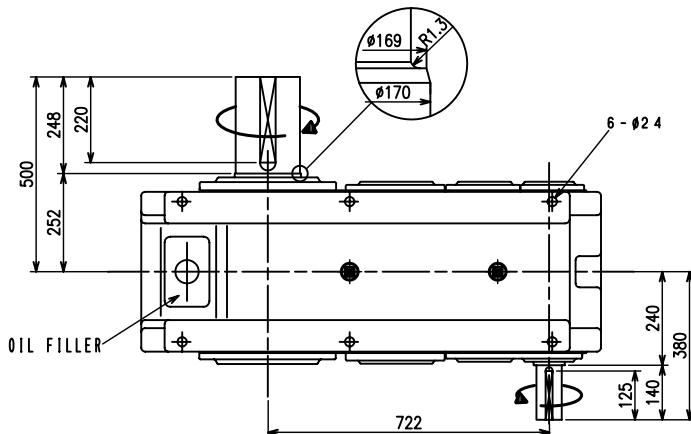

## SCREW PRESS DRIVE 20T (P20) REDUCER SPECIFICATIONS

Model	Ratio	Torque Rating Nm	Input Speed rpm	Output Speed rpm	Power Rating kW	Output Shaft dia mm	Input Shaft Dia mm	Weight (Approx) kg	Oil Qty (Approx) l
YHD080P3SP-LR-76.353	76.353	74,000	1000	13.1	100	165	65	1,000	65
			750	9.8	75				

Lubrication System: Oil Bath  
Lubricant: ISO VG220 AGMA 7EP

# Screw Press Drive P20

YHD070P3SP-RL-77.373

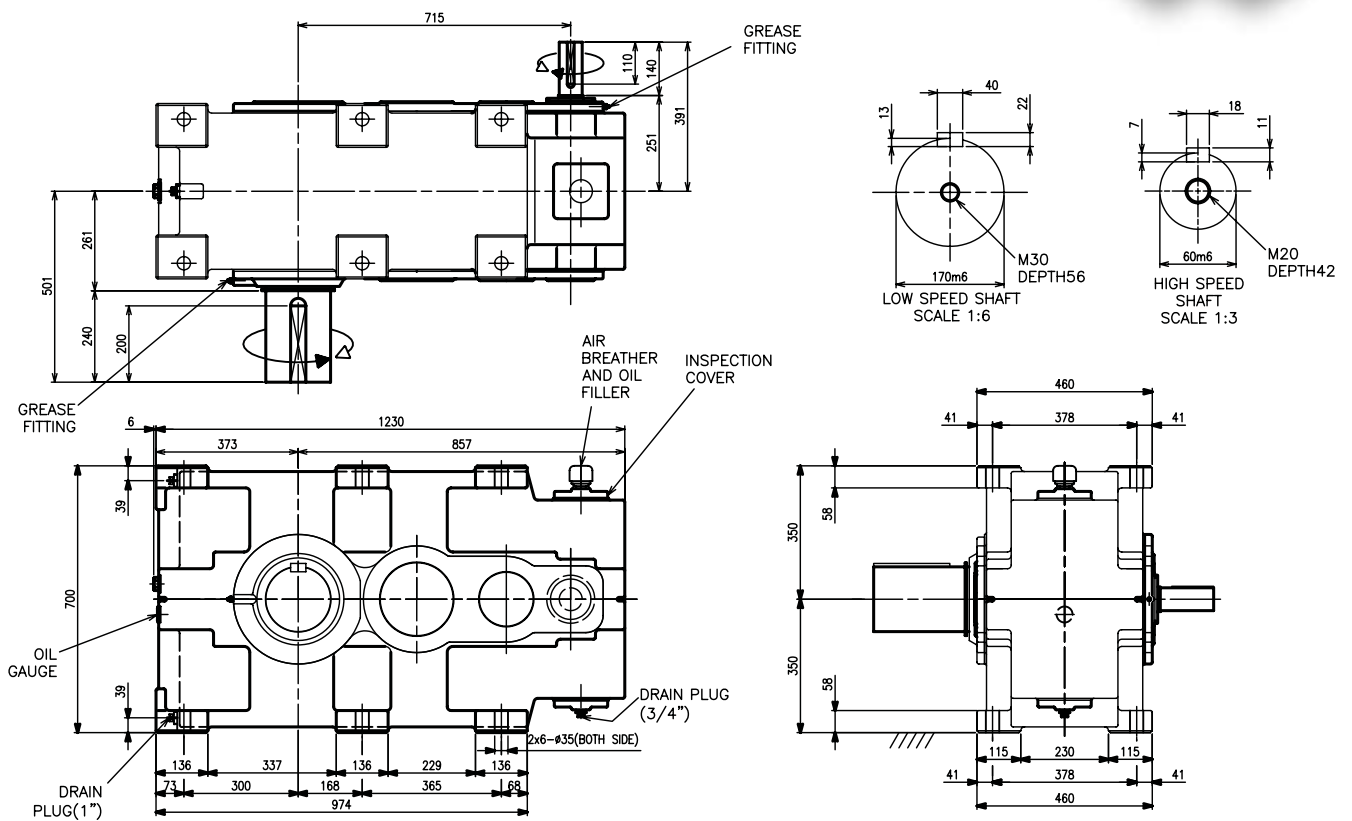
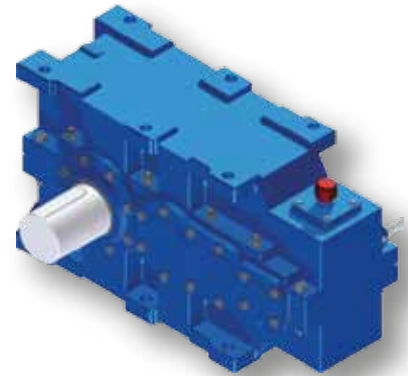

## SCREW PRESS DRIVE 20T (P20) REDUCER SPECIFICATIONS

Model	Ratio	Torque Rating Nm	Input Speed rpm	Output Speed rpm	Power Rating kW	Output Shaft dia mm	Input Shaft Dia mm	Weight (Approx) kg	Oil Qty (Approx) l
YHD070P3SP-RL-77.373	77.373	70,000	1000	12.9	95	170	60	1,080	85
			750	9.7	71				

Lubrication System: Oil Bath  
Lubricant: ISO VG460 AGMA 7EP

# Digester Drive 3000L

YVA040P3DG-RL-57.962

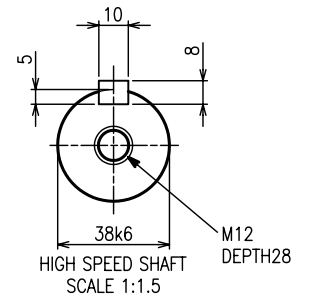
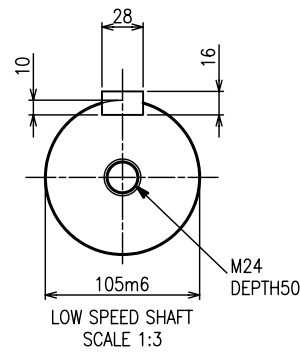
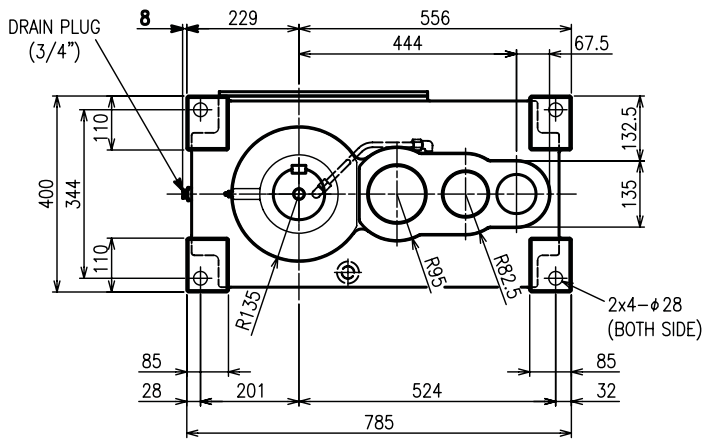
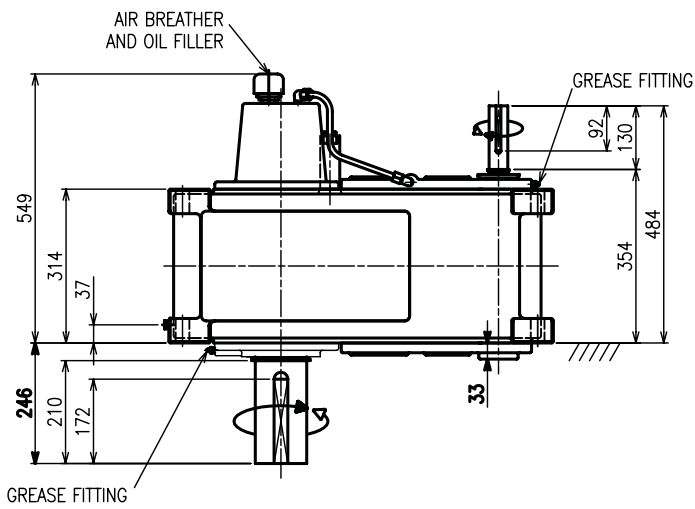
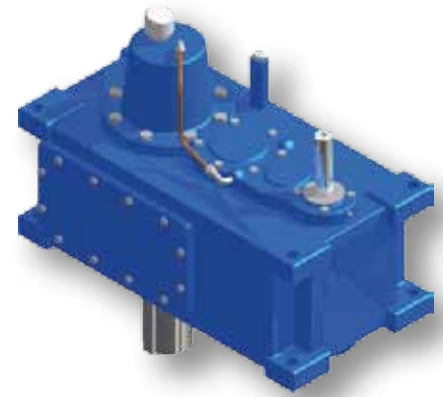

## DIGESTER DRIVE 3000L REDUCER SPECIFICATIONS

Model	Ratio	Torque Rating Nm	Input Speed rpm	Output Speed rpm	Power Rating kW	Output Shaft dia mm	Input Shaft Dia mm	Weight (Approx) kg	Oil Qty (Approx) l
YVA040P3DG-RL-57.962	57.962	18,000	1500	25.9	49	105	38	380	50

Lubrication System Oil Bath  
Lubricant ISO VG460 AGMA 7EP



# Digester Drive 6000L

YVD060P3DG-RL-57.328

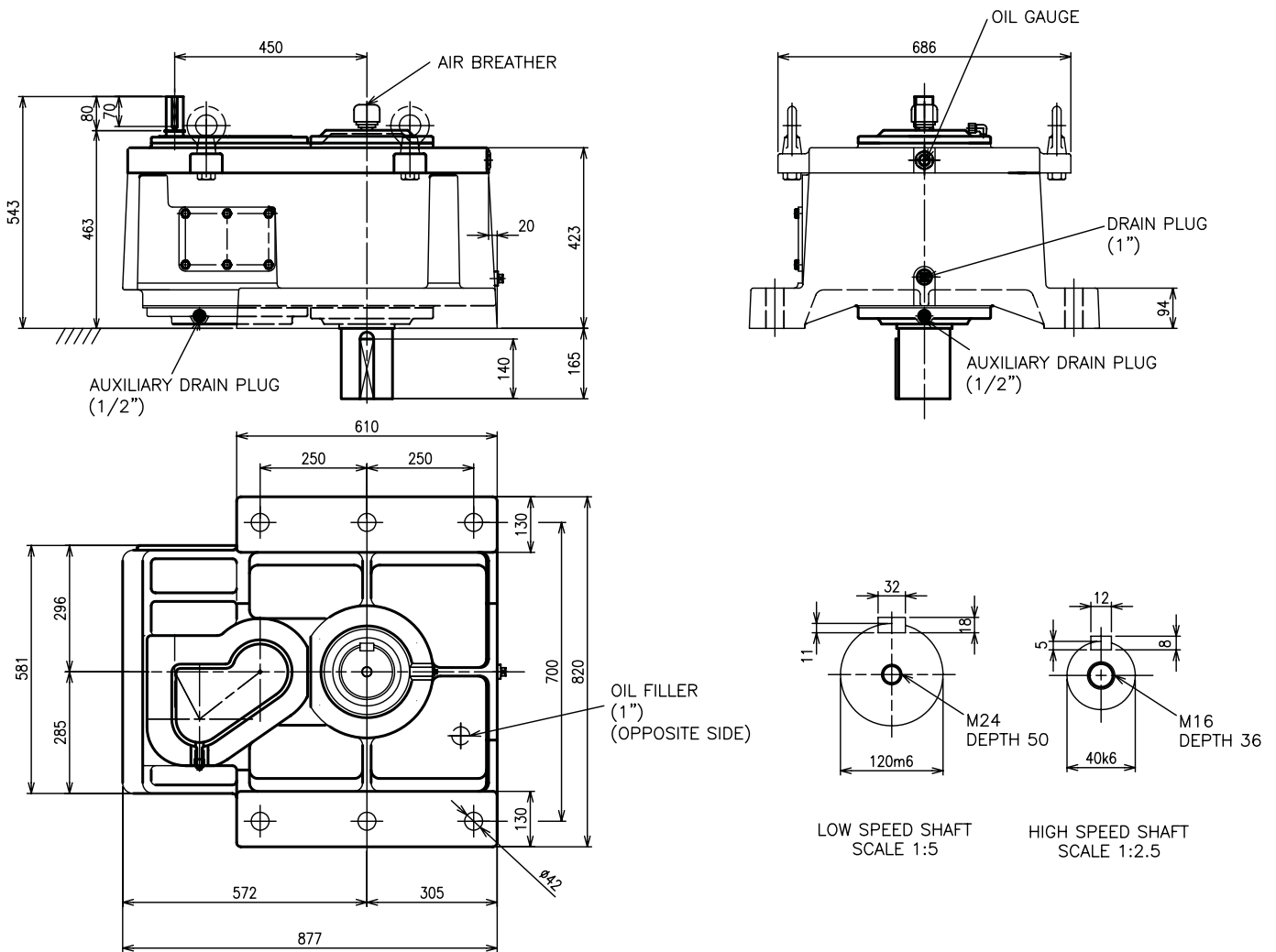
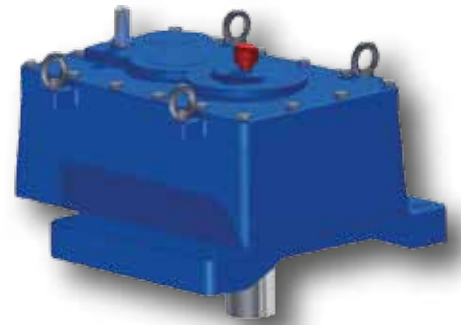

## DIGESTER DRIVE 6000L REDUCER SPECIFICATIONS

Model	Ratio	Torque Rating Nm	Input Speed rpm	Output Speed rpm	Power Rating kW	Output Shaft dia mm	Input Shaft Dia mm	Weight (Approx) kg	Oil Qty (Approx) l
YVD060P3DG-RL-57.328	57.328	32,000	1500	26.2	88	120	40	830	100

Lubrication System  
Lubricant

Oil Bath  
ISO VG460 AGMA 7EP

# Empty Fruit Bunch Press Drive

YHD080P3-LR-55.066

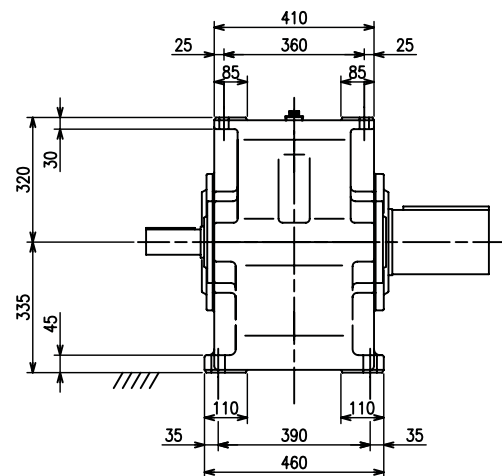
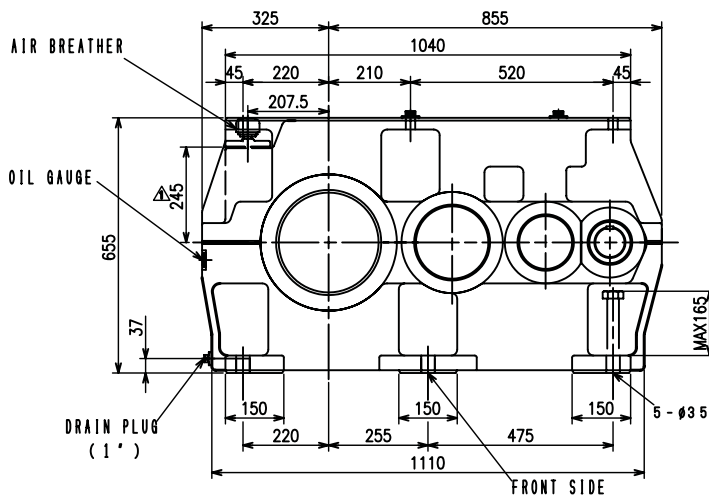
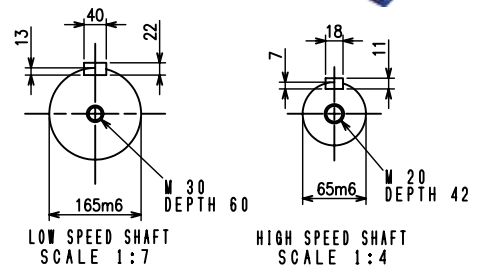
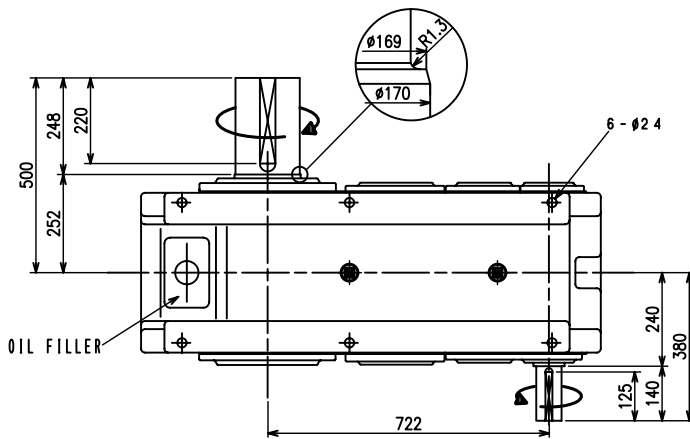

## EMPTY FRUIT BUNCH PRESS REDUCER SPECIFICATIONS

Model	Ratio	Torque Rating Nm	Input Speed rpm	Output Speed rpm	Power Rating kW	Output Shaft dia mm	Input Shaft Dia mm	Weight (Approx) kg	Oil Qty (Approx) l
YHD080P3-LR-55.066	55.066	74,000	1000	18.2	140	165	65	1,000	65
			750	13.6	105				

Lubrication System  
Lubricant

Oil Bath  
ISO VG220 AGMA 7EP



Sumitomo's Speed reducers and geared motors are available **EX-STOCK** in **Malaysia, Indonesia, Thailand and Singapore.**

Suitable for any **Palm Oil Mill** and **Kernel Press** drive requirements, our products are **warranted for two years\*** irrespective of hours of operations.

With over **30 YEARS** of **EXPERIENCE** in the **Palm Oil Industry**, we strive to be a **DEPENDABLE** partner for your power transmission solutions, providing not only **VALUE FOR YOUR MONEY** but also a peace of mind!

\*Sumitomo Cyclo, BBB and HBB reducers and geared motors are warranted for 24 months from the date of shipment or 18 months from the date of coming into operation, whichever earlier. Other products are warranted for 18 months from the date of shipment or 12 months from the date coming into operation, whichever earlier. Details are available on Terms and Condition of Purchase. Please contact Sumitomo.



Screw Press • Digester • Thresher • KCP • Empty Bunch Press • Capstan • Conveyors

# Asia Pacific Network:

## SINGAPORE

(Asia Pacific Headquarter)

### Sumitomo (SHI) Cyclo Drive Asia Pacific Pte Ltd

15 Kwong Min Road,  
Singapore 628718  
Tel: +65 6591 7800  
Fax: +65 6863 4238  
Email: inquiry@sumitomodrive.com.sg

## AUSTRALIA

### SM-Cyclo of Australia Pty Ltd

9 Holbeche Road  
Ardell Park NSW 2148  
Tel: +61 2 8811 6555  
Fax: +65 2 8811 6500  
Email: sales@sumitomo-drive.com.au

## INDIA

### Sumi - Cyclo Drive India Pvt Ltd

Survey No. 130, Hissa No. 02, Jeevan Nagar, (Next to TVS logistics, Off Mumbai Bangalore Bypass) Tathawade, Pune 411 033  
Tel: +91 20 6674 2900  
Fax: +91 20 6674 2901  
Email: sumicyclo@vsnl.net

## INDONESIA

### Sumitomo (SHI) Cyclo Drive Asia Pacific Pte Ltd

Indonesia Representative Office  
Wisma GKBI, #1606,  
Jl. Jend. Sudirman, no. 28  
Jakarta 10210, Indonesia  
Tel: +62 21 5795 2120  
Fax: +62 21 5795 1210  
Email: inquiry@sumitomodrive.com.sg

## Distributors In Asia Pacific

### MALAYSIA

#### Bintulu:

#### Himalaya Power Transmission Sdn Bhd

Ground Floor, Sublot 4,  
Lot 1175, Block 32, Bintulu-Miri Road,  
Kemena Land District, 97000 Bintulu,  
Sarawak  
Tel: +60 86 311930  
Fax: +60 86 311039  
Email: hptbtu@tm.net.my

#### Sandakan:

#### Himalaya Power Transmission Sdn Bhd

Ground Floor, Block B, Lot 8, Mile 7 1/2  
Labuk Road, PPM 582 Elopura, 90000  
Sandakan, Sabah  
Tel: +60 89 672700  
Fax: +60 89 675711  
Email: hptsdk@tm.net.my

#### Kuantan:

#### CKR Industrial Equipment Sdn Bhd

(601399-V)  
No 17, Jalan IM 3/5, Mohkota Industrial Park,  
Bandar Indera Mahkota, 25200 Kuantan,  
Pahang D M  
Tel: +60 9 5736035 / 7035  
Fax: +60 9 5738035  
Email: ckr@pd.jaring.my

#### Johor:

#### Euro-Tech Asia International Sdn Bhd

**WISMA EURO-TECH**  
2912-A, Jalan Merbau 3,  
Bandar putra, 81000 Kulaijaya,  
Johor, West Malaysia.  
Tel: +607-599 7811  
Fax: +607-598 7811  
Email: sales@eutechinternational.com

## MALAYSIA

### Kuala Lumpur (Head Office)

No.7C, Jalan Anggerik Mokara 31/56,  
Kota Kemuning, Seksyen 31, 40460  
Shah Alam, Selangor D.E.  
Malaysia  
Tel: +60 3 5121 0455  
Fax: +60 3 5121 0578  
Email: smmasupport@smma.shi.co.jp

### Johor

24-02, Jalan Ros Merah 2/17  
Taman Johor Jaya 81100 JB, Johor  
Tel/Fax: (60) 7 357 2909

### Lahad Datu

1st Floor MDLD  
7151 Bandar Sri Perdana Phase 3  
91100 Lahad Datu, Sabah  
Tel / Fax: (60) 89 863 909

### Penang

No. 2945, First Floor, Jalan Prai,  
Taman Inderawasih, 13600 Prai,  
Penang  
Tel/Fax: (60) 4 390 6386

## PHILIPPINES

### Sumitomo (SHI) Cyclo Drive Asia Pacific Pte Ltd

Philippines Branch Office  
B2b Granville Industrial Complex,  
Governor's Drive, Bo. Bancal  
Carmona, Cavite 4116, Philippines  
Tel: +63 46-43820579 - 81  
Fax: +63 46-4303592  
Email: all@smph.sumitomodrive.com

## THAILAND

SM-Cyclo of Thailand Co., Ltd.  
195 Empire Tower Unit 2103-4  
21th Floor South Sathorn Road,  
Yannawa, Bangkok 10120, Thailand  
Tel: (66) 2670 0998  
Fax: (66) 2670 0999

## VIETNAM

### Sumitomo (SHI) Cyclo Drive Asia Pacific Pte Ltd

**Ho Chi Minh Representative Office**  
7th Floor, 301 Tran Hung Dao St.,  
Co Giang Ward, Dist. 1, HCMC  
Tel: +84 8 3920 4539/40  
Fax: +84 8 3920 4540  
Email: inquiry@sumitomodrive.com.sg

### Hanoi Representative Office

Room 603, 6th Floor, NOZA Building  
243 Cau Giay Street  
Cau Giay District, Hanoi City  
Tel/Fax: +84 4 767 2470  
Email: inquiry@sumitomodrive.com.sg

## JAPAN

(World Headquarter)

### Sumitomo Heavy Industries Ltd.

ThinkPark Tower, 1-1 Osaki 2-Chome  
Shinagawa-ku, Tokyo 141-6025 Japan  
Tel: +81 3 6737 2511  
Fax: +81 3 6866 5160

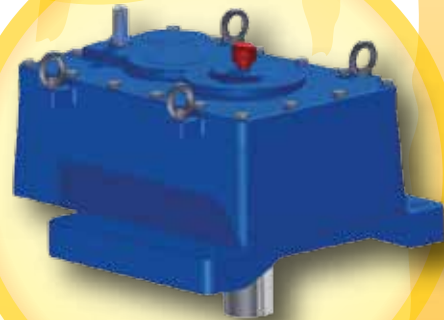
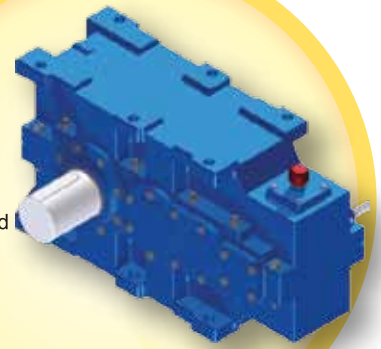

For global contacts, please visit  
[www.sumitomodrive.com](http://www.sumitomodrive.com)